

# ICC-ES Evaluation Report

**ESR-2494**

Reissued September 2025

Revised April 2026

This report also contains:

- [City of LA Supplement](#)

Subject to renewal September 2027

ICC-ES Evaluation Reports are not to be construed as representing aesthetics or any other attributes not specifically addressed, nor are they to be construed as an endorsement of the subject of the report or a recommendation for its use. There is no warranty by ICC Evaluation Service, LLC, express or implied, as to any finding or other matter in this report, or as to any product covered by the report.

Copyright © 2026 ICC Evaluation Service, LLC. All rights reserved.

<p><b>DIVISION: 03 00 00 - CONCRETE</b></p> <p><b>Section: 03 21 00— REINFORCEMENT BARS</b></p>	<p><b>REPORT HOLDER: POHLCON USA INC</b></p>	<p><b>EVALUATION SUBJECT: DECON® STUDRAILS®</b></p>	
---	--	---	---

## 1.0 EVALUATION SCOPE

### Compliance with the following codes:

- 2018, 2015 2012, 2009 and 2006 [International Building Code® \(IBC\)](#)
- 2013 *Abu Dhabi International Building Code (ADIBC)*†

†The ADIBC is based on the 2009 IBC. 2009 IBC code sections referenced in this report are the same sections in the ADIBC.

### Property evaluated:

- Structural

## 2.0 USES

Decon® Studrails® are used as shear reinforcement in flat concrete slabs to replace stirrups, drop panels or column capitals in increasing the punching shear resistance of the slabs.

## 3.0 DESCRIPTION

### 3.1 General:

Decon® Studrails® are large-head shear studs that are welded to steel plates. The assembly complies with the requirements of ASTM A1044. The available stud sizes and corresponding head dimensions are shown in [Table 1](#).

### 3.2 Materials:

**3.2.1 Shear Studs:** The shear studs are formed from ASTM A29 Grades 1010 through 1020 steel and conform to the following physical and mechanical requirements prescribed in [Table 1](#) of ASTM A1044:

- Yield strength: 51,000 psi (350 MPa), minimum.
- Tensile strength: 65,000 psi (450 MPa), minimum.
- Elongation: 20 percent in 2 inches (51 mm).
- Reduction of area: 50 percent, minimum.
- Dimensions of the shear studs are shown in [Table 1](#).

**3.2.2 Base Rails:** The rails are formed from CSA 44W steel and conform to the following physical and mechanical requirements of Table 2 of ASTM A1044:

- Yield strength: 44,000 psi (300 MPa), minimum.
- Tensile strength: 65,000 psi (450 MPa), minimum.
- Elongation: 20 percent in 8 inches (203 mm).
- Dimensions of the shear studs are shown in [Table 1](#).

**3.2.3 Stud Welding:** The studs are factory-welded to the rails in conformance with ASTM A1044, AWS D1.1 and the PohlCon quality documentation.

## 4.0 DESIGN AND INSTALLATION

### 4.1 General:

Installation of the stud/plate assemblies must comply with the applicable provision of ACI 318-14 for the 2018 and 2015 IBC (ACI 318-11 for the 2012 IBC and ACI 318-08 for the 2009 and 2006 IBC), and the approved plans. The specified yield strength of transverse reinforcement,  $f_{yt}$ , must not exceed the specified yield strength of the shear studs defined in Section 3.2.1 of this report.

The structural design must determine and specify the following items, based on design requirements in this report:

- a. The number of studs per rail
- b. Stud spacing(s)
- c. Studrail overall assembly height (OAH)
- d. Rail length (OAL)
- e. Distance between column face and first line of studs ( $s_o$ )
- f. Stud size
- g. Stud/rail material specifications
- h. Rail thickness, width and length

### 4.2 Earthquake-resistant Structures:

**4.2.1 General:** The provisions in this section apply to structures in Seismic Design Categories C, D, E, and F. Lateral force-resisting elements of the structure must be designed in accordance with the IBC.

**4.2.2 Shear Strength:** The applicable provisions of ACI 318-014 for the 2018 and 2015 IBC (ACI 318-11 for the 2012 IBC and ACI 318-08 for the 2009 and 1006 IBC) shall apply except the nominal shear strength provided by concrete in the presence of the headed shear stud reinforcement referenced in Section 22.6.6.1 of ACI 318-14 for the 2018 and 2015 IBC (Section 11.11.5.1 of ACI 318-11 for the 2012 IBC and ACI 318-08 for the 2009 and 2006 IBC), must be revised as follows:

$$V_c = 1.5\lambda\sqrt{f'_c}(b_0d) \quad \text{Eq. (1)}$$

This revision requires the nominal shear strength,  $V_n$ , and the nominal shear stress,  $v_n$ , to be revised accordingly.

Two-way slabs without beams not designated as part of the seismic-force-resisting system must comply with Section 18.14.5.1 of ACI 318-14 for the 2018 and 2015 IBC (Section 21.13.6 of ACI 318-11 for the 2012 IBC and ACI 318-08 for 2009 and 2006 IBC), except that  $V_c$  must be limited as set forth in Eq. (1) of this report, and the design story drift ratio specified in Section 18.14.5.1 of ACI 318-14 for the 2018 and 2015 IBC (Section 21.13.6(b) of ACI 318-11 for the 2012 IBC and ACI 318-08 for the 2009 and 2006 IBC) must not exceed the drift ratio specified in Table 12.12-1 of ASCE/SEI 7-16 for the 2018 IBC (ASCE/SEI 7-10 for the 2015 and 2012 IBC and ASCE/SEI 7-05 for the 2009 and 2006 IBC).

### 4.3 Installation:

Installation must comply with IBC Chapter 19 and the approved engineering plans. Concrete cover must comply with Section 20.6.1.3.5 of ACI 318-14 for the 2018 and 2015 IBC (Section 7.7.5 of ACI 318-11 for the 2012 IBC and ACI 318-08 for the 2009 and 2006 IBC). [Figure 1](#) shows typical details.

### 4.4 Special Inspection:

Special inspection of studrails and their installation at the jobsite must comply with Section 1705.3 of the 2018, 2015 and 2012 IBC (Section 1704.4 of the 2009 and 2006 IBC). The special inspector is responsible for verifying identification of the studrail per Section 7.0 of this report, along with its condition, location, positioning, clearances, and concrete cover.

## 5.0 CONDITIONS OF USE:

The Decon<sup>®</sup> Studrails<sup>®</sup> described in this report comply with, or are suitable alternatives to what is specified in, those codes noted in Section 1.0 of this report, subject to the following conditions:

- 5.1 The welded and fabricated shear stud reinforcement plate assemblies must be designed and installed in accordance with the applicable code, this report (Sections 4.1 and 4.2 for structural design; Section 4.3 for installation) and the manufacturer's instructions. In case of conflict between the manufacturer's published installation instructions and this report, this report governs.
- 5.2 Calculations and details demonstrating that the applied loads are less than the resistance of the reinforced concrete must be submitted to the code official for approval. Calculations and details must be prepared by a registered design professional where required by the statutes of the jurisdiction in which the project is to be constructed.
- 5.3 The design for the finished assemblies must specify the details described in Section 4.1.
- 5.4 Special inspection must be provided in accordance with Section 4.4 of this report.
- 5.5 The studrails are fabricated at the PohlCon USA Inc., facility located in Ontario, Canada, under a quality control program with inspections by ICC-ES.

## 6.0 EVIDENCE SUBMITTED

Data in accordance with the [ICC-ES Acceptance Criteria for Headed Shear Stud Reinforcement Assemblies for Concrete Slabs or Footings \(AC395\)](#), dated June 2017 (editorially revised November 2017).

## 7.0 IDENTIFICATION

- 7.1 Decon<sup>®</sup> Studrails<sup>®</sup> are identified on packaging with the part name, part number, manufacturer's name and address, and evaluation report number (ESR-2494).
- 7.2 The report holder's contact information is the following:

**POHLCON USA INC**  
**35 DEVON ROAD**  
**BRAMPTON, ONTARIO L6T 5B6**  
**CANADA**  
**(866) 332-6687**  
[www.pohlconusa.com](http://www.pohlconusa.com)

TABLE 1—DECON<sup>®</sup> STUDRAIL<sup>®</sup> DIMENSIONS

D	X-sect. area	D <sub>head</sub>	t <sub>head</sub>	b <sub>rail</sub>	t <sub>rail</sub>
in. (mm)	in <sup>2</sup> (mm <sup>2</sup> )	in. (mm)	in. (mm)	in. (mm)	in. (mm)
3/8 (9.5)	0.110 (71)	1.19 (30.1)	0.21 (5.3)	1 (25.4)	3/16 (4.8)
1/2 (12.7)	0.196 (127)	1.58 (40.2)	0.28 (7.1)	1-1/4 (31.8)	1/4 (6.5)
5/8 (15.9)	0.307 (199)	1.98 (50.2)	0.35 (8.9)	1-3/4 (44.5)	5/16 (7.9)
3/4 (19.1)	0.442 (287)	2.37 (60.2)	0.42 (10.7)	2 (50.8)	3/8 (9.5)

Note: Overall height (OAH) of the stud is determined by the slab thickness and the required concrete cover.

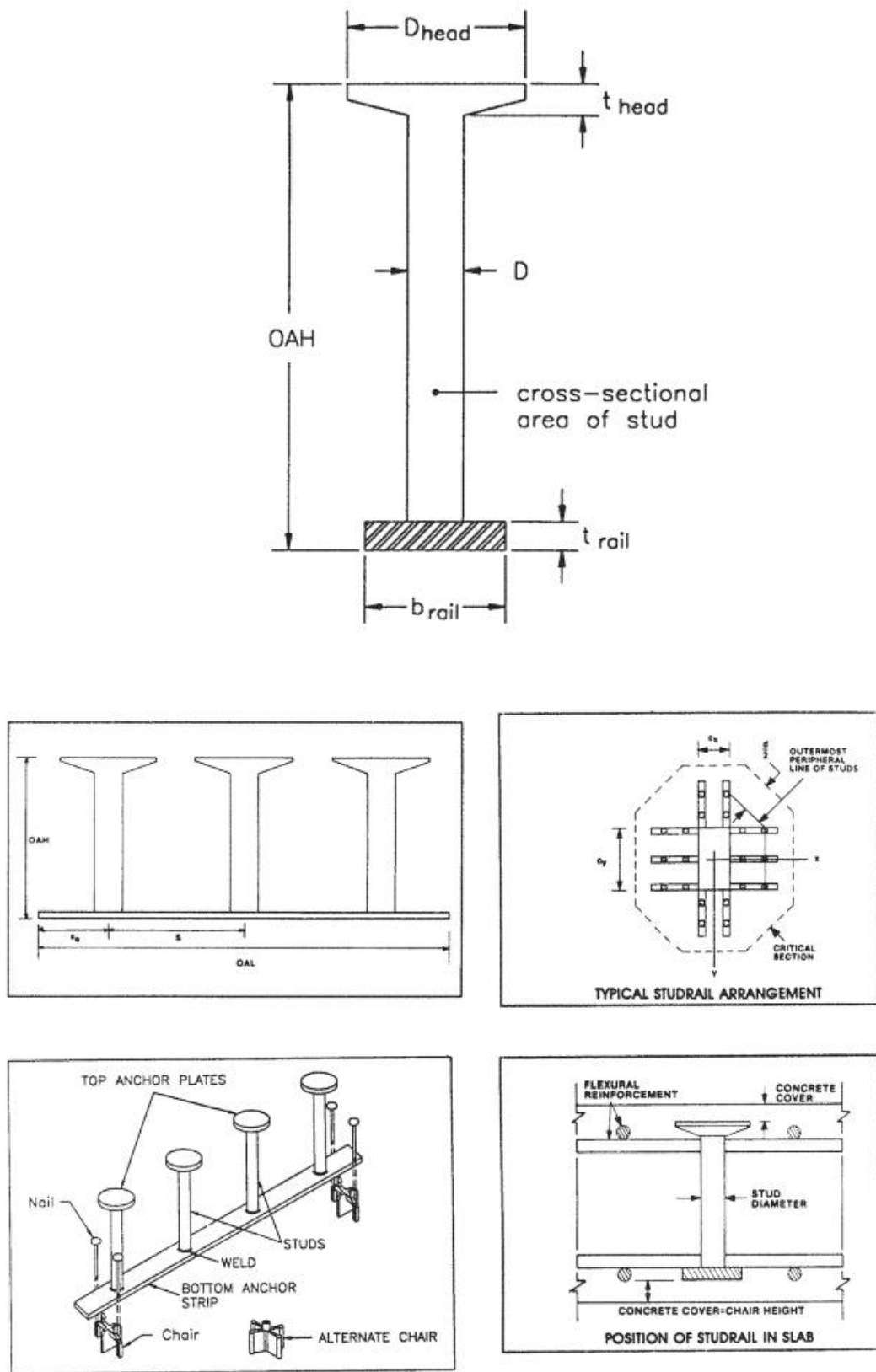

FIGURE 1—TYPICAL DETAILS

**DIVISION: 03 00 00—CONCRETE**  
**Section: 03 21 00—Reinforcement Bars**

**REPORT HOLDER:**

POHLCON USA INC.

**EVALUATION SUBJECT:**

DECON® STUDRAILS®

**1.0 REPORT PURPOSE AND SCOPE****Purpose:**

The purpose of this evaluation report supplement is to indicate that Decon® Studrails®, described in ICC-ES evaluation report [ESR-2494](#), have also been evaluated for compliance with the code noted below as adopted by the Los Angeles Department of Building and Safety (LADBS).

**Applicable code edition:**

- 2020 *City of Los Angeles Building Code* ([LABC](#))

**2.0 CONCLUSIONS**

The Decon® Studrails®, described in Sections 2.0 through 7.0 of the evaluation report [ESR-2494](#), comply with LABC Chapter 19, and is subjected to the conditions of use described in this report.

**3.0 CONDITIONS OF USE**

The Decon® Studrails® described in this evaluation report supplement must comply with all of the following conditions:

- All applicable sections in the evaluation report [ESR-2494](#).
- The design, installation, conditions of use and labeling of the Decon® Studrails® are in accordance with the 2018 *International Building Code*® (IBC) provisions noted in the evaluation report [ESR-2494](#).
- The design, installation and inspection are in accordance with additional requirements of LABC Chapters 16 and 17, as applicable.

This supplement expires concurrently with the evaluation report, reissued September 2025 and revised April 2026.